



# GLOBAL PILING EQUIPMENT INC.

936.494.4200 tel • 491 Conroe Park W. Dr. • Conroe, TX 77303  
Sales@Pileco.com • www.Pileco.com

## Specifications: D 36-32 Diesel Pile Hammer

### Dimensions approx:

Length of Hammer:	A1	5600 mm	18' 4" ft
Hammer length w/starter guides:	A	6400 mm	21' ft
Outer diameter of impact block:	B	660 mm	2' 2" ft
Min. Guiding Width:	C	813 mm	32" in
Width of hammer:	D	785 mm	31" in
Hammer Center to Pump Guard:	F	445 mm	1' 6" ft
Hammer Center to Trip:	G	275 mm	11" in
Hammer Depth:	H	848 mm	2' 9" ft

Pump Setting 1	55.7 kNm	40,935 ft.lbs.
Pump Setting 2	75.4 kNm	55,410 ft.lbs.
Pump Setting 3	94.8 kNm	69,680 ft.lbs.
Pump Setting 4	114 kNm	83,860 ft.lbs.

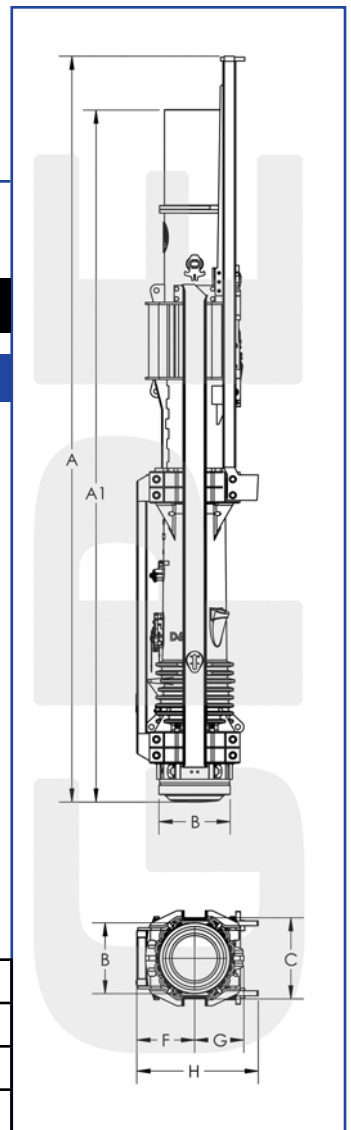

### Weights approx:

Weight of diesel pile hammer approx.:	10.85 US tons	21,705 lbs
Weight of piston approx.:	3600 kg	7,936.7 lbs
Impact Block approx.:	1070 kg	2,359 lbs
Tripping device approx.:	500 kg	1102.3 lbs
Tool box approx.:	100 kg	220.5 lbs

### Energy per blow

Max:	114 kNm	83,860 ft lbf
Min:	55.5 kNm	40,935 ft lbf
Number of blows:		36-52 min

### Batter Info

Max. gradient of batter pile driven: 1:3/1:1

### Consumption

Diesel fuel:	11.5 L hr.	3 gph
Lubrication oil:	2 L hr.	.53 gph

### Volume

Diesel oil tank:	89 L	23.5 gal
Lube tank:	17 L	4.5 gal