

**8000413 U-32 Single Line Head Block
with 3 Sheaves**
Parts Manual

Parts Manual

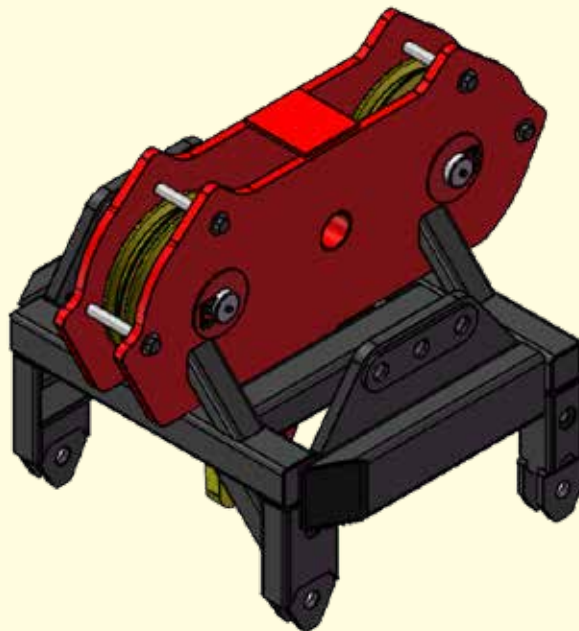

TOTAL WEIGHT APPROX: 2,679 LBS

U-32 SINGLE LINE HEAD BLOCK WITH 3 SHEEVES

pages 3-4

LUBRICATION MAINTENANCE

page 5

U-32 SINGLE LINE HEAD BLOCK WITH 3 SHEEVES

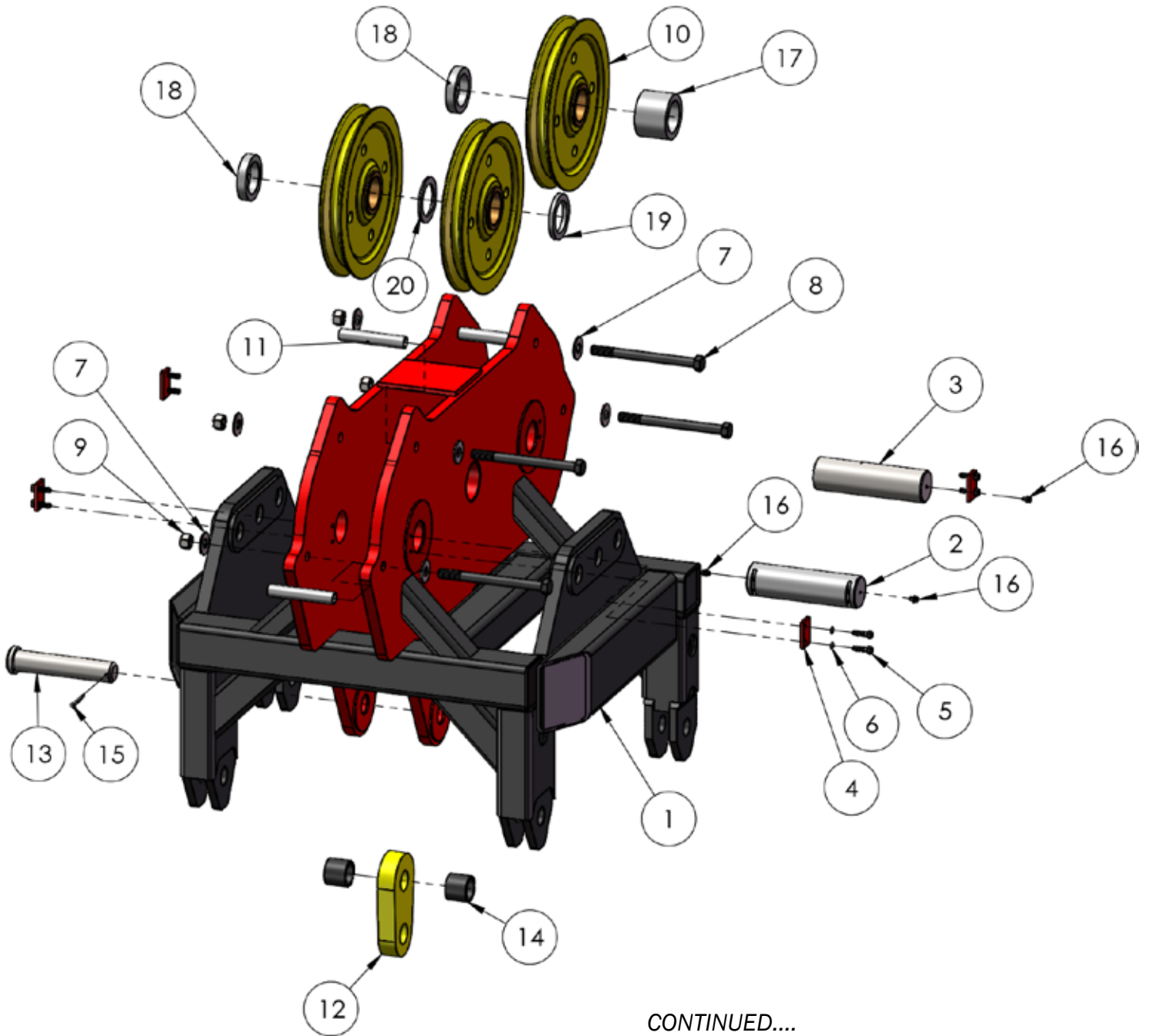

CONTINUED....

U-32 SINGLE LINE HEAD BLOCK WITH 3 SHEEVES

ITEM NO.	PART NO.	DESCRIPTION	QTY.
1	8000406-MACHINE	U-32 SINGLE LINE HEAD BLOCK -MACHINE	1
2	8004280	SHEAVE WHEEL SHAFT	1
3	8004283	SHEAVE WHEEL SHAFT	1
4	8001606	LOCKING PLATE	4
5	8001634	1/2-13 X 1 3/4 HEX HEAD CAPSCREW GR 8	8
6	203110	12MM SCHNORR SAFETY WASHER	8
7	8000638	1" FLATWASHER	8
8	8001671	1-8 X 12 HEX HEAD CAP SCREW GR5	4
9	8000470	1-8 NYLON INSERT LOCKNUT	4
10	41839	ROPE PULLEY FOR 1 1/8 WIRE ROPE	3
11	8004281	1" x 7 1/2 SCH 40 PIPE	4
12	8001637	PLATE	1
13	8004291	PIN	1
14	8001672	2 1/2 X 2.375 SCH 80 PIPE	2
15	90637	8 X 80 COTTER PIN	1
16	90791	GREASE NIPPLE M10 X 1	3
17	8004284	SPACER	1
18	8004285	SPACER	2
19	8004286	SPACER	1
20	8004287	SPACER	1

Visual Inspections

1. All equipment shall be checked every 6 months for wear and cracks
2. Check all welds for cracking and fatigue
3. Bearings shall be inspected for unusual wear and replaced if needed
4. Hoses shall be replaced if cracks or leakage occur

**RECOMMENDED LUBRICANT:
MOBILITH SHC 220 GREASE**

LUBRICATION MAINTENANCE SCHEDULE:	DAILY	6 MONTHS	ANNUALLY
GREASE ALL SHEAVES	•		
REPACKING OF BEARINGS			•

REPACKING OF BEARINGS MUST BE DONE MANUALLY. PLEASE REFER TO SKF FOR PROPER PACKING OF BEARINGS.